



**IF IT FAILS, WE'LL REPLACE IT. GUARANTEED!\***

# Diamond Gard® Installation Instructions

## Mitsubishi Electric Heavy Duty Starter

### **WARNING**

Understand and follow safety procedures as outlined by your shop or employer whenever working with this product, including wearing proper eye protection. Remove all metal jewelry prior to any repair of the starting system. Failure to do so may result in serious and permanent injury. The components listed in these instructions may continue to have power supplied to them even when the ignition switch is in the off position.

### **DANGER**

Disconnect the vehicle's battery ground cables at the battery before any service to the starting system. Failure to disconnect the battery ground cables can result in serious and permanent injury.

If a spacer was used between the old starter and flywheel housing, ensure it is installed with the new starter. Failure to do so may result in pinion meshing problems and subsequent damage.



If dielectric grease or other corrosion-inhibiting product is applied to terminals, apply AFTER tightening terminals to proper torque. This procedure ensures low resistance connections.

If replacing a starter with an IMS (Integrated Magnetic Switch), the replacement starter should have an IMS. Always connect the control lead to the IMS terminal if so equipped. Failure to do so may result in undesired performance.

### Step 1 - Starter Removal

- 1) Disconnect all ground cables connected to the vehicle's batteries
- 2) Remove cables connected to starter's ground and B-terminal and note cable locations for reinstallation
- 3) Remove the cable connected to the IMS-terminal or Sw-terminal
- 4) Remove three mounting bolts connecting starter to engine

### Step 2 - Ring Gear Wear Check

- 1) Check the engine's ring gear for wear before installing a new starter. If wear is excessive, the ring gear should be replaced.

Due to six cylinder diesel engine design characteristics, the ring gear will come to rest in one of three positions. Check all three ring gear positions for wear, commonly called "barring over".

### Step 3 - Starter Motor Reinstallation

- 1) Install new starter by reversing steps used for removal
  - Properly torque mounting bolts
  - Connect battery cable to starter's B Terminal
  - Connect ground cable to starter's Ground Terminal
  - See page 2 for ground cable installation details
  - Control circuit lead to starter's Sw or IMS terminal
  - Always connect to the IMS terminal if starter is so equipped
- 2) Protect starter motor's pinion from impacts during installation
  - Roughness on pinion surfaces can lead to ring gear engagement errors

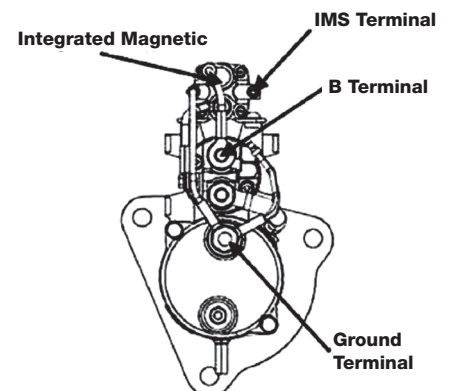

Terminal Locations - Starter Equipped with IMS

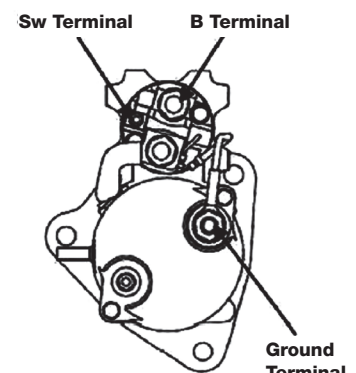

Terminal Locations - Starter Equipped without IMS

**Step 4 - Final Visual Check:**

- 1) Visually inspect starting system's electrical connections
- 2) There should be no gaps between the starter flange and the flywheel housing
- 3) Improper mounting can lead to:
  - Damaged pinion and ring gear
  - Stuck pinion
  - Engagement errors
  - Premature starter failure

Starter Torque Specifications	B	Ground	IMS	SW	Mounting Bolts				
	All Applications				Mack/Volvo 11L	Mack/Volvo 13L & 15L	All Other Engine Applications		
Truck Make	All Applications				Mack/Volvo 11L	Mack/Volvo 13L & 15L	All Other Engine Applications		
Size	M12	M12	M5/M6	M5	M10	M12	11mm (SAE 1)	13.5mm (SAE 3)	17mm
lb. ft.	15-20	15-22	2.2-2.7	1.5-1.8	30-42	52-74	22-44	33-66	74-147
lb. in.	180-264	180-264	26-44	18-22	—	—	—	—	—
N.m.	20-30	20-30	3-5	2.0-2.5	40-56	70-100	30-60	45-90	100-200

**Ground Cable Installation Detail**

Mitsubishi Electric starters are shipped with an extra nut to protect the ground terminal's threads during shipping. This extra nut can be discarded after removal from the starter's ground terminal.

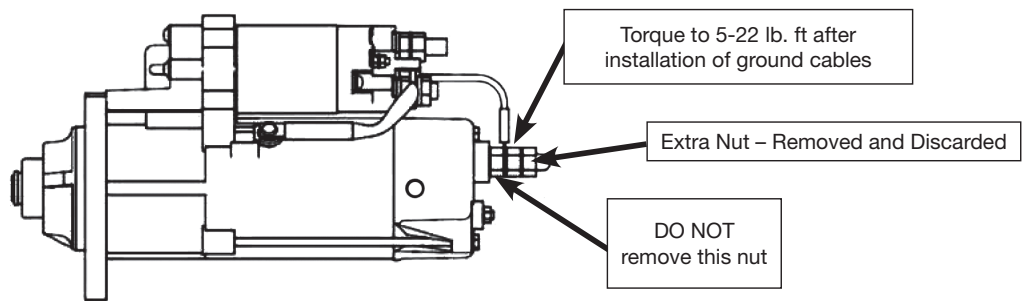

**Over Crank Protection (OCP) Starter Conversion Instructions:**

When replacing an OCP starter with one not including OCP, the OCP is not needed and the existing connector must be shorted. This can be accomplished in 1 of 2 ways. If an OCP Bypass Connector is included refer to (A). If an OCP Bypass Connector is not included refer to (B).

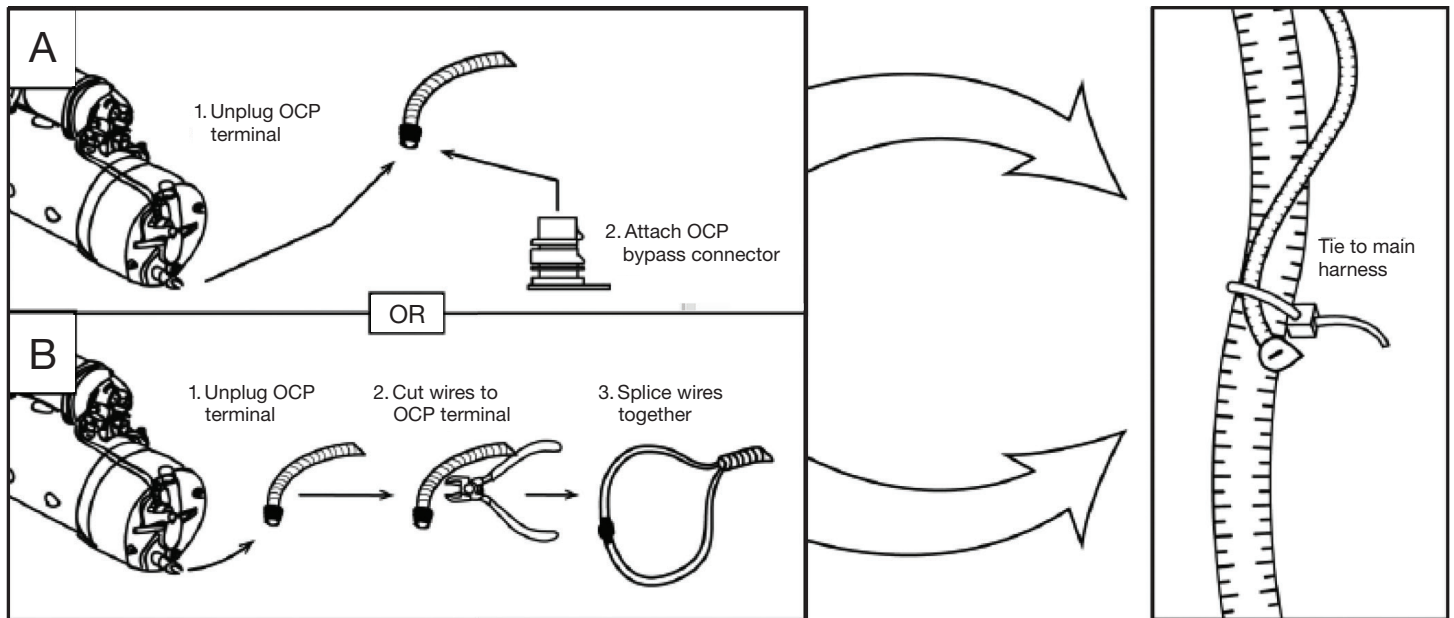

**IF IT FAILS, WE'LL REPLACE IT. GUARANTEED!\***

\* For more information visit: [diamond-gard.com](http://diamond-gard.com) or phone customer service at: 888-635-2648

© 2024 Mitsubishi Electric Automotive America, Inc.